

GVC Series

*Vertical, Cantilevered Pump
For Flows to 2,500 GPM*

 **Carver[®]**

Creating Value.

The GVC Series

The GVC Series is Carver's new vertical pump series for handling fluids at moderate to high flow rates. The standard design is a cantilever style unit, with a top pull-out option also available.

The GVC is based on the same product platform as our vertical sump and horizontal, end suction pumps. Hydraulic performance extends to 2,500 GPM at 1,750 RPM and is covered by twenty-five sizes in cast iron, 316 SS fitted, and all 316 SS construction. For added simplicity, the entire series is based on only three bearing frames and can be had in whole pump or modular kit form.

Both the cantilevered and top pull-out designs are offered in two standard column depths. The *standard* column setting has a 12 inch drop between the bottom of the mounting plate and back of the pump casing. The *extended* column setting, on the other hand, is twice this length, giving a 24 inch drop between the bottom of the mounting plate and back of the pump casing.



The basic GVC design consists of a pumping (wet) end, bearing frame, motor mounting bracket and top plate. All models feature external impeller adjustment, bearings above the liquid surface, no mechanical seals to maintain, full compatibility with standard NEMA 'C' face motors, and some of the most efficient hydraulics in the industry.

Common options include discharge piping (standard, oversized and double oversized), 316 SS underliners, suction strainers and inlet tail pipes.

Along with these, duplex pumping units and accessories such as automatic greasers and control panels with float switch actuators and automatic start/stop sequencing are also available.

Most importantly, as with all our other pumps, the GVC offers the reliability, low total life cost, and lasting value that has made Carver one of the most trusted names in pumps.

Hydraulics

- Flows to 2,500 US GPM (570 m³/hr)
- Efficiencies to 85%
- Solids to 1.250" diameter (32 mm)
- Power to 150 HP (110 KW)
- Speeds to 3,500 RPM

Applications

- Acids and solvents transfer
- E-coat systems
- Fluid filtering
- Large vehicle washers
- Lubrication for rotating equipment
- Machine coolant recovery
- Spray paint systems
- Parts washers circulation
- Ultra high purity water wash systems
- Various other proprietary systems



Modular Construction

1520 Bearing Frame

Up to 3500 RPM / 20 HP

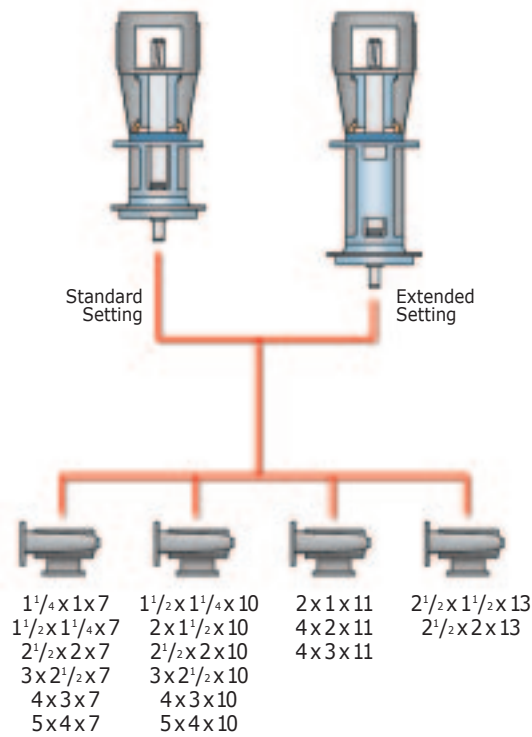

1530 Bearing Frame

Up to 1750 RPM / 75 HP

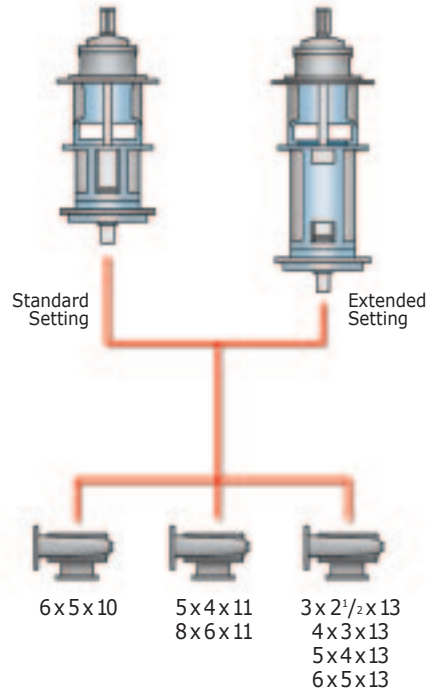

1540 Bearing Frame

Up to 1750 RPM / 150 HP

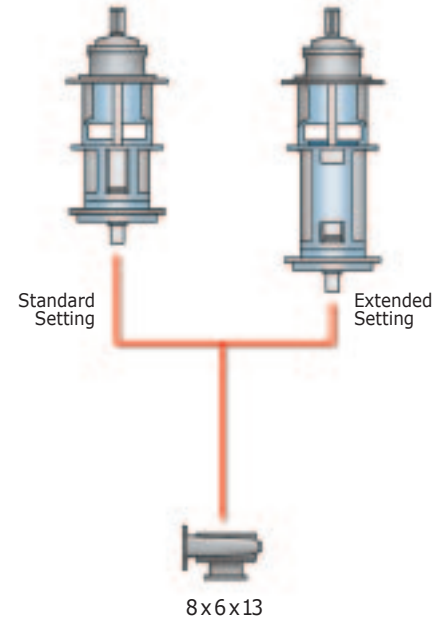

The simple design of the GVC is augmented by its modular construction. All twenty-five sizes are based on only three bearing frames and share most of the same parts as our other industrial product lines.

Top Pull-out Option

Center of gravity lift-out allows removal of all rotating elements, and inspection of the shaft, impeller, throttle bushing and/or bearings, without otherwise disturbing the column-to-top plate or discharge piping connections.

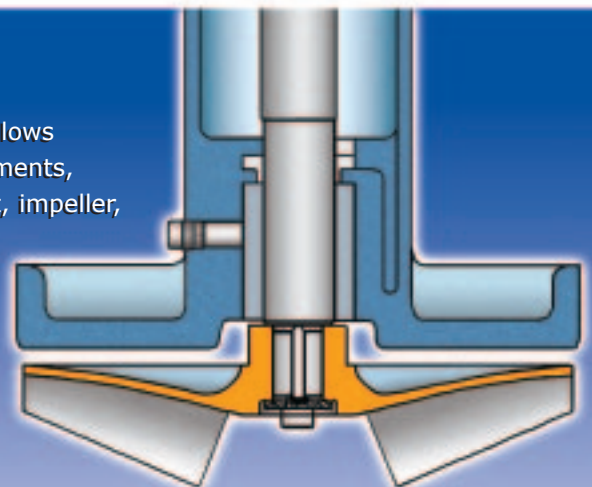

Features & Benefits

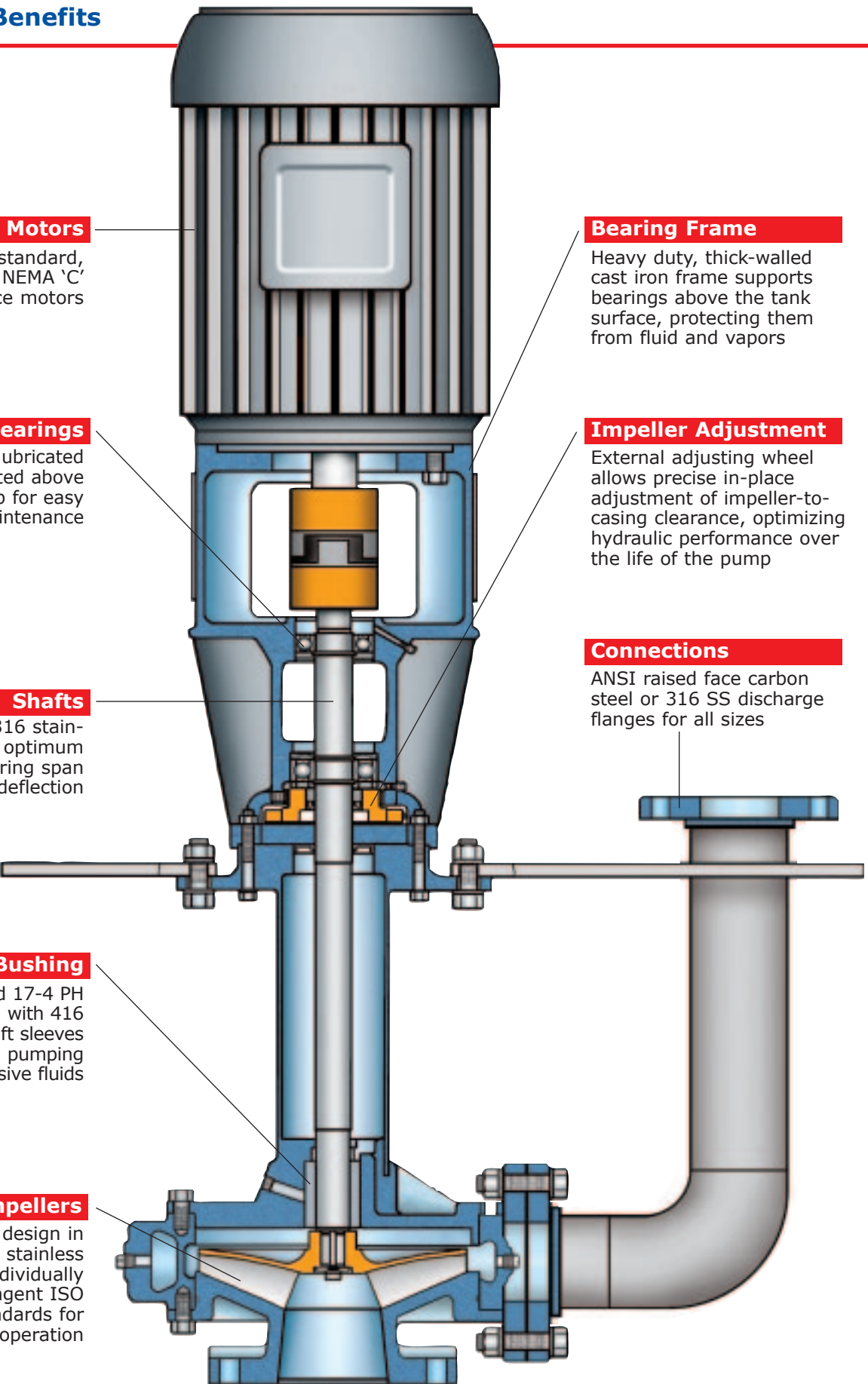

Motors

Operation with standard, easily available NEMA 'C' face motors

Bearing Frame

Heavy duty, thick-walled cast iron frame supports bearings above the tank surface, protecting them from fluid and vapors

Ball Bearings

Oversized, grease lubricated ball bearings located above tank top for easy maintenance

Impeller Adjustment

External adjusting wheel allows precise in-place adjustment of impeller-to-casing clearance, optimizing hydraulic performance over the life of the pump

Shafts

Carbon steel or 316 stainless steel, with optimum diameter and bearing span for minimal deflection

Connections

ANSI raised face carbon steel or 316 SS discharge flanges for all sizes

Throttle Bushing

Teflon or hardened 17-4 PH stainless steel with 416 stainless steel shaft sleeves for longer life when pumping dirty or abrasive fluids

Impellers

High efficiency design in cast iron or 316 stainless steel – individually balanced to stringent ISO G2.5 standards for vibration-free operation

Hydraulic Coverage @ 1750 RPM

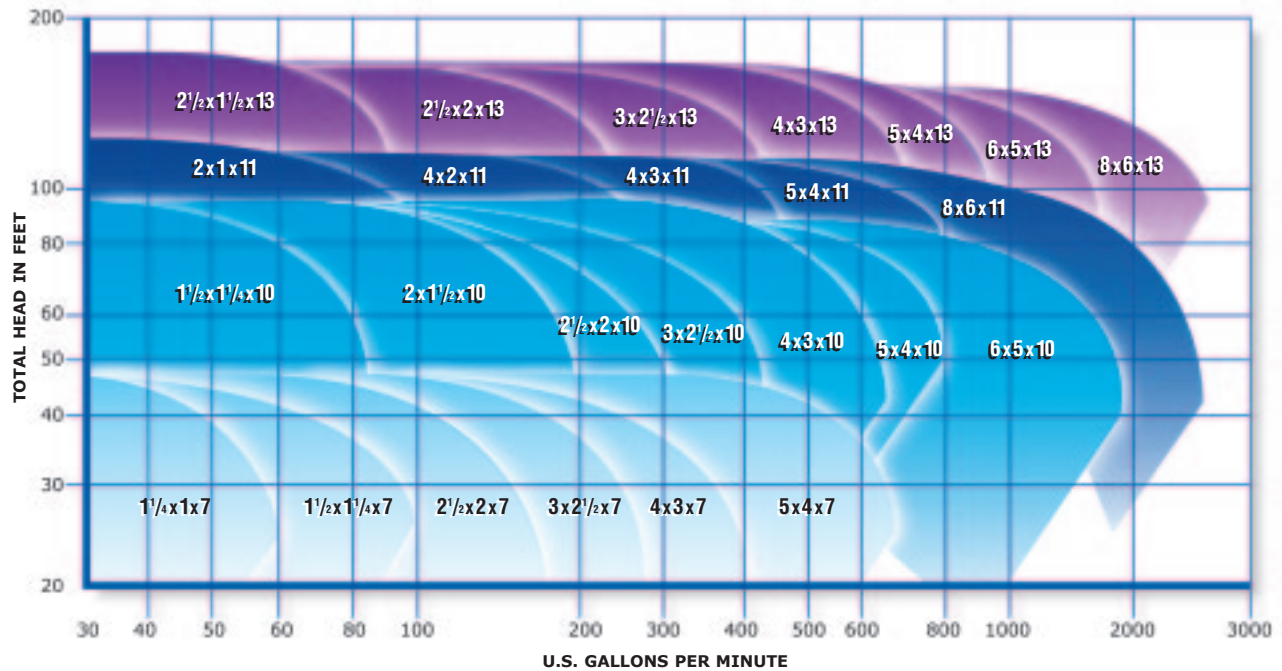

Why A GVC?

Along with all of its technical advantages, the GVC also offers the indirect benefits of:

- robust designs with the same reliability and quality that we have been providing the United States military for the past 60 years
- extensive standard and optional features that assure total flexibility in meeting system installation and hydraulic performance requirements
- backing by over 70 stocking distributors, sales agents, and certified service centers – the largest aftermarket support group for pumps of this type in the world.

There are many things to consider when selecting a vertical pump. However, in the end it all comes down to value, and the GVC delivers more of it than any other pump.

To see for yourself, contact us or any of our stocking distributors.

Standard Materials

Casing	Cast iron or 316 SS
Impeller	Cast iron or 316 SS
Piping	Carbon steel or 316 SS
Throttle Bushing	Teflon or 17-4 PH SS
Top Plate.....	Carbon steel or 316 SS
Shaft.....	Carbon steel or 316 SS
Shaft Sleeve.....	416 SS

Mechanical Data

Rotation.....	CW as standard
Input Power	Up to 150 HP
Discharge Connection	ANSI 150 lb. flange
Bearing Lubricant.....	Grease as standard
Radial Bearing L ₁₀ Life	50,000 hours
Thrust Bearing L ₁₀ Life	25,000 hours



Approval Certification Number 95-370

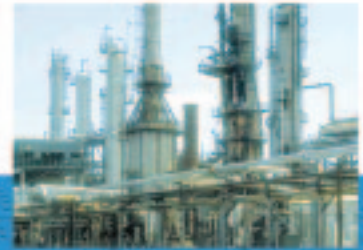

Since we built our first pumps in 1938, the Carver name has become synonymous with value. Today we are recognized as one of the world's leading centrifugal pump companies, building pumps to the most demanding engineering specifications and military standards in the world.

Our company is located in Muscatine, Iowa, 25 miles southwest of the Quad Cities area. Our operations there include some of the most modern manufacturing equipment and pump development software available, and we are committed to the highest quality possible in our products and our people. Along these lines, Carver was also one of the first American pump companies to attain ISO 9001 certification—the most recognized standard for quality in the world.

From an applications standpoint Carver has traditionally built pumps for water, oil, and chemicals for both the public and private sectors. Our product line includes both horizontal and vertical end suction, multi-stage, axial split case, self-priming, API, and solids-handling pumps that all carry the same Carver trademark: lasting value from solid, straightforward designs engineered to provide many years of service.

These pumps are also backed by unparalleled aftermarket support. Our network of stocking distributors, manufacturer's representatives and certified service centers throughout the world means that no matter where your pump may be installed, there are local sales and service people ready to support your aftermarket needs.



Carver Pump Company

2415 Park Avenue • Muscatine, IA 52761
563.263.3410 • Fax: 563.262.0510

www.carverpump.com

