



MILTON ROY

Milroyal D Disc Diaphragm

Low Flow Liquid End

INSTRUCTION

MANUAL

339-0063-000

Issued 08/10

TABLE OF CONTENTS

Table of Contents.	i
Section 1 Description.	1
General	1
Principle of Operation.	1
Safety Precautions.	1
Model Coding.	1
Section 2 Storage.	3
Short Term Storage (Less than 6 Months).	3
Long Term Storage (Longer than 6 Months)	3
Pump Drive and Gearboxes.	3
Pneumatic, Electrical and Electronic Equipment.	3
Section 3 Installation.	5
Unpacking.	5
Mounting.	5
Liquid End Conversion Procedures	5
Piping.	5
Piping Concentrated Sulfuric Acid	6
Suction Lift Conditions	6
Section 4 Operation.	9
Initial Start-up.	9
Maintenance	10
Section 2 Troubleshooting Guide	13

LIST OF ILLUSTRATIONS

Figure 1. Model Code	2
Figure 2. Data Plate.	2
Figure 3. Standard Dimensions.	4
Figure 4. Typical Sludge Trap.	7
Figure 5. Typical Installation.	7
Figure 6. Milroyal D Disc Diaphragm Liquid END TOP View.	14
Figure 7. Milroyal D Disc Diaphragm Liquid END Section View.	15
Figure 8. Double Ball Suction & Discharge Valve (Used Before 01/01/01).	18
Figure 9. Single and Double Ball Check Valve Assy (Used Before 01/01/01 and 01/01/02) .20	
Figure 10. Double Ball Suction & Discharge Valve (Used After 01/01/02).	22
Figure 11. Refill Valve Assembly	24
Figure 12. Relief Valve Assembly	25

SECTION 1

DESCRIPTION

The instruction manual is designed to serve as a supplement to instruction manual 339-0010-000, which provides both general information and specific instructions for installing, operating, and maintaining Milroyal pumps. This manual covers only the optional Low Flow Disc Diaphragm Liquid Ends which may be fitted to these pumps in place of the standard Packed Plunger or HPD Liquid Ends. Do not rely on this manual alone in installing, maintaining, and operating Milroyal pumps.

GENERAL

The Low Flow Disc Diaphragm Liquid End is particularly suitable for pumping costly, aggressive, or hazardous liquids without leaking. The diaphragm is hydraulically balanced between the process liquid on one side and the hydraulic oil on the other side. The hydraulic oil takes the place of a mechanical connection between pump plunger and diaphragm.

PRINCIPLE OF OPERATION

In a Disc Diaphragm Liquid End, the reciprocating pump plunger alternately forces hydraulic oil against the diaphragm and then draws the oil back into the plunger bore. This action causes the diaphragm to flex between the limiting contour plates.

Each suction stroke of the plunger pulls the diaphragm towards the oil side contour plate so that process liquid flows into the displacement chamber through the suction ball-check valve. Each discharge stroke of the plunger pushes the diaphragm towards the process side contour plate to expel the process liquid from the displacement chamber through the discharge ball-check valve. On each suction stroke, the discharge ball-checks are seated, and on each discharge stroke, the suction ball-checks are seated (pressure in pump head is greater than suction line pressure). This mode of operation prevents back flow and ensures liquid movement from the suction port, through the diaphragm head, and out the discharge port. Precise hydraulic oil volume is maintained by an

automatic air-bleed valve and a refill valve.

SAFETY PRECAUTIONS

When installing, operating, and maintaining the Disc Diaphragm Liquid End, keep safety considerations foremost. Use proper tools, protective clothing, and eye protection when working on the equipment and install the equipment with a view toward ensuring safe operation. Follow the instructions in this manual and take additional safety measures appropriate to liquid being pumped. Be extremely careful in the presence of hazardous substances (e.g. corrosives, toxins, solvents, acids, caustics, flammables, etc.)

MODEL CODING

See Figure 1 to determine the specific features and ratings of a specific Milroyal D disc diaphragm pump. The model code can be found on the product data plate (see Figure 2) which is mounted on each pump (see Figure 3)

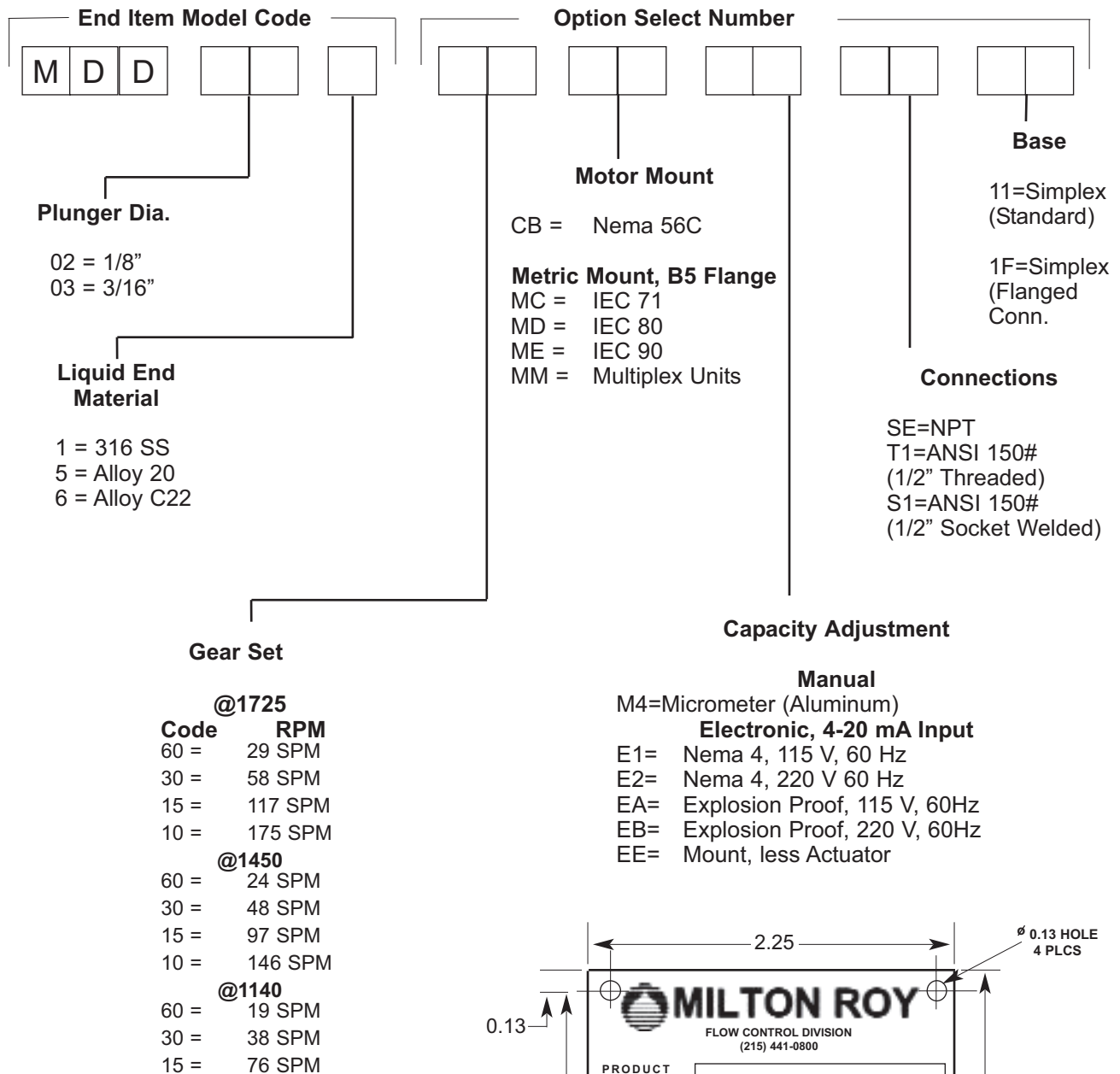

Figure 1. Model Code

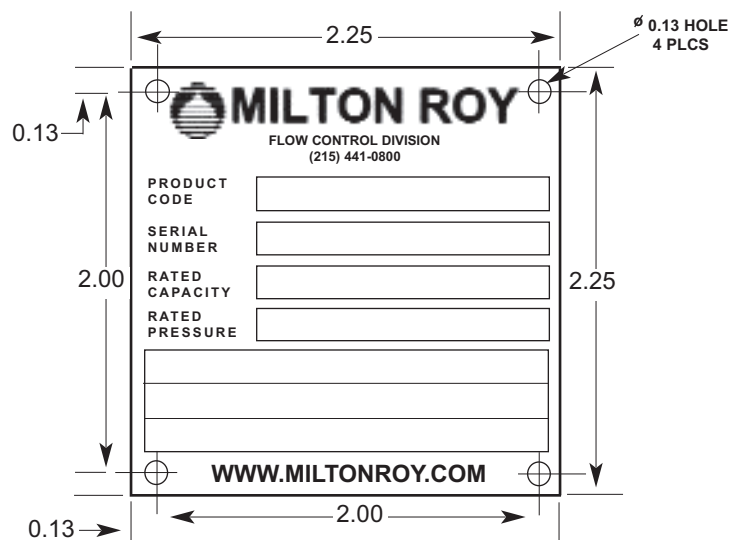

Figure 2. Data Plate

SECTION 2 STORAGE

STORAGE

Short Term Storage (Less than 6 Months)

It is preferable to store the material under a shelter in its original package to protect it from adverse weather conditions. In condensing atmospheres, follow the long term storage procedure.

Long Term Storage (Longer than 6 Months)

The primary consideration in storage of pump equipment is to prevent corrosion of external and internal components. This corrosion is caused by natural circulation of air as temperature of the surroundings change from day to night, day to day, and from season to season. It is not practical to prevent this circulation which carries water vapor and other corrosive gasses, so it is necessary to protect internal and external surfaces from their effects to the greatest extent possible.

When the instructions given in this section are completed, the equipment is to be stored in a shelter; protected from direct exposure to weather. The prepared equipment should be covered with a plastic sheet or a tarpaulin, but in a manner which will allow air circulation. Equipment should be stored 12 inches or more above the ground.

If equipment is to be shipped directly from Milton Roy into long term storage, contact Milton Roy to arrange for factory preparation.

Pump Drive and Gearboxes

A. Flood the gearbox compartment with a high grade lubricating oil/rust preventative such as Mobile Oil Corporation product Mobilarma 524. Fill the compartment completely to minimize air space and water vapor condensation. After storage, drain this material and refill the equipment with the recommended lubricant for equipment commissioning.

B. Remove drive motors and mounting adapters, and brush all unpainted metal surfaces with multi-purpose grease (NLGI grade 2 or 3). Store these unattached.

Pneumatic, Electrical and Electronic Equipment

A. Motors should be prepared in the manner prescribed by their manufacturer. If information is not available, dismount and store motors as indicated in step "B" below.

B. For all pneumatic and electrical equipment, place packets of Vapor Phase Corrosion Inhibitor (VPCI) inside of the enclosure, then place the entire enclosure, with additional packets, inside a plastic bag. Seal the bag tightly closed. Contact Milton Roy Service Department for recommended VPCI materials.

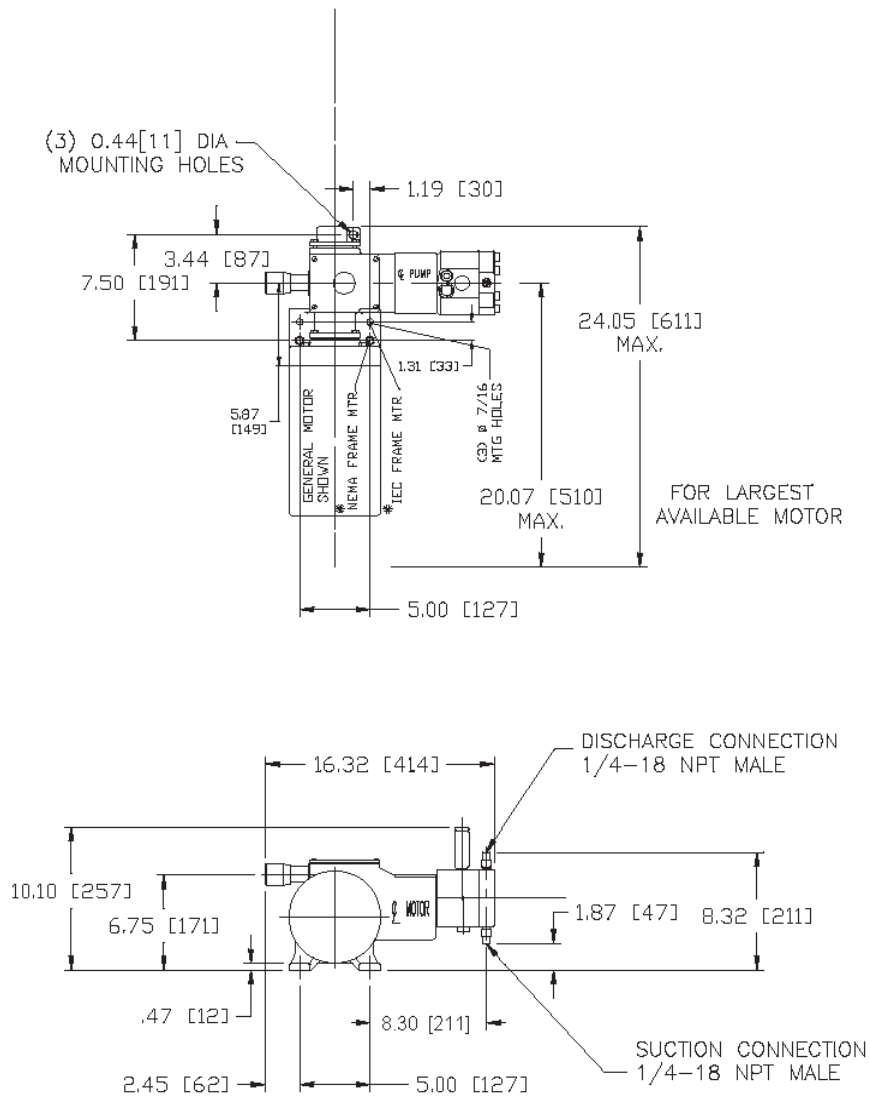

Figure 3. Standard Dimensions

SECTION 3 INSTALLATION

UNPACKING

Units are shipped Ex Works , Ivyland , Pa. and the title passes to the customer when the carrier signs for receipt of the unit. In the event that damages occur during shipment, it is the responsibility of the customer to notify the carrier immediately and to file a damage claim. Carefully examine the shipping crate upon receipt from the carrier to be sure there is no obvious damage to the contents. Open the crate carefully so accessory items fastened to the inside of the crate will not be damaged or lost. Examine all material inside the crate and check against the packing list to be sure that all items are accounted for and intact.

MOUNTING (Refer to Figure 3)

Milroyal D pumps should be firmly mounted in a level position on a solid foundation, preferable with the base above floor level to protect it from wash downs and provide easier access for service. This model pump is provided with three tie-down points to accommodate anchor bolts. Table-top operation is possible without need for tie-down with 1/8 or 3/16" plunger diameter liquid end. Up to six units can be easily multiplexed to a single standard motor without special support.

LIQUID END CONVERSION:

(IF YOU PURCHASED A NEW PUMP THAT HAS A DISC DIAPHRAGM ALREADY INSTALLED, PROCEED TO PIPING.)

To convert a pump from standard Packed Plunger Liquid End to Disc Diaphragm Liquid End, study the drawings at the back of this manual and then mount the liquid end to the pump as follows).

MILROYAL D CONVERSION STEPS (SEE FIGURE 7

Disassembly

1. Remove Packed Plunger Liquid End assembly from pump (see pump drive disassembly instructions in instruction manual 339-0010-000).
2. Remove plunger adapter, gland cap, gland studs or bolts, and funnel.

Reassembly

1. Slide plunger adapter over plunger.
2. Insert plunger assembly in bore of displacement chamber.
3. Carefully fit liquid end assembly to pump housing bore while guiding plunger adapter into threaded hole in crosshead.
4. Thread three mounting bolts into displacement chamber from inside pump catchall and tighten securely. Use pipe dope on the upper most screw to insure a proper oil seal.
5. Bottom the plunger firmly in plunger adapter against crosshead and then tighten adapter securely.
6. Proceed to start-up instructions in Section 4.

PIPING

General piping instructions are given below. Additional information is provided in pump drive instruction manual 339-0010-000. No reciprocation plunger pump can be expected to perform satisfactorily unless all recommendations are followed.

GENERAL INFORMATION

Use piping materials that are resistant to corrosion by the liquid being pumped. Use care in selection of materials to avoid galvanic corrosion at points of connection to the pump liquid end.

Use piping sufficiently heavy to withstand maximum pressures.

Blow out all lines before making final connections to pump.

Provide for pipe expansions when hot fluids are to be pumped. Support piping so that pipe weight is not placed on the pump. Never spring piping to make connections.

Piping should be sloped in a manner to prevent tapping of vapor pockets. Vapor present in liquid

end will cause inaccurate pump delivery.

SUCTION PIPING

If possible use metal or plastic tubing for the suction line because tubing has a smooth inner surface and can be formed into sweep bends, thus decreasing frictional flow losses.

Suction piping must be absolutely air tight to insure accurate pumping. After installation, test suction piping with air and soap solution for leaks.

A strainer should be used in the suction line to prevent foreign particles from entering the liquid end. Any measures which prevent foreign matter from entering and fouling the ball checks will give increased maintenance free service.

It is preferable to have the suction of the pump flooding by having the liquid end located below the level of the fluid in the supply tank.

When pumping liquids at temperatures near the boiling point, provide sufficient suction head to prevent "flashing" of the liquid into vapor when it enters the liquid end on the suction stroke.

When suction piping is long, particularly at stroke speeds greater than 70 strokes per minute, the size of the piping should be larger than the liquid end suction fitting to prevent starving the pump.

Sealed piping, sufficient suction pressure, and properly adjusted packing are absolutely necessary for accurate and stable pump operation.

DISCHARGE PIPING

Install adequate size pump to prevent excessive pressure losses on the discharge stroke of the pump. Maximum pressure at the discharge fitting on the liquid end must be kept at or below the maximum pressure rating as shown on the pump data plate. The peak flow of this type of pump during the discharge stroke is approximately three times the average flow rate (because of harmonic motion of the plunger) and discharge piping should be sized accordingly.

The pump will not deliver a controlled flow if the discharge pressure is less than the suction pressure. Piping should be arranged to provide at least 5 psi (34.5 kPa) positive pressure differential from the discharge side to the suction side. There are a number of ways to create an artificial discharge pressure, such as the use of a vented riser or a back pressure valve.

PIPING CONCENTRATED SULFURIC ACID

The liquid ends of pumps with plungers less than 5/8" in diameter, designed for 20 gph delivery or less, are too small to tolerate the sludge in commercial concentrated sulfuric acid. However, even these pumps will serve in such applications if the piping system is modified as follows:

1. Install a sulfuric acid tank, which has an unused portion below the tank outlet to the suction line to collect sludge from the system. (Maximum pressure/sludge trap is 20 psig.)
2. Ensure pump suction is flooded.
3. Use piping material identical to liquid end material: install steel pipe to steel liquid end. Never connect iron to steel or serious galvanic corrosion will occur.
4. Filter sludge by installing a glass wool filter or Milton Roy Sludge Trap in the suction line.

The first and last of these precautions will benefit any size pump by removing the high proportion of sludge in this acid, which can foul or clog pump check valves.

Figure 4 illustrates a typical sludge trap and Figure 5 indicates a typical installation showing a strainer (Sludge trap) near the tank.

SUCTION LIFT CONDITIONS

Disc Diaphragm Liquid End pumps are designed to operate with process liquid supplied at or above atmospheric pressure. Although these pumps can move liquids supplied at less than atmospheric pressure, the resulting suction lift must remain constant. The intent is that the piping must be

designed to provide an adequate net positive suction head (NPSH). Obtain our NPSH Calculation software at the Milton Roy Web site (miltonroy.com). If assistance in determining NPSH is needed, contact the Milton Roy Aftermarket Service department.

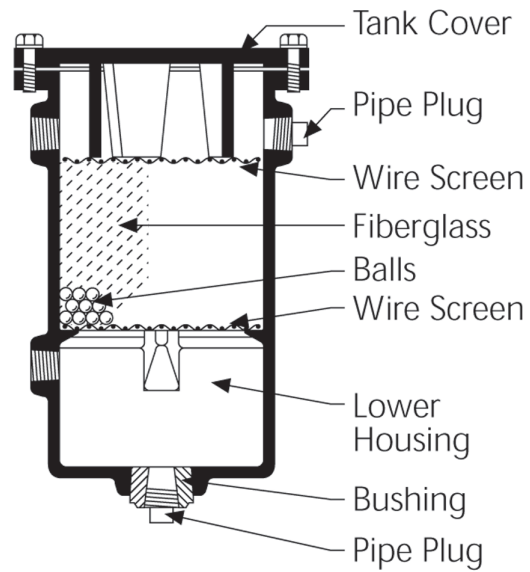

Figure 4 Typical Sludge Trap

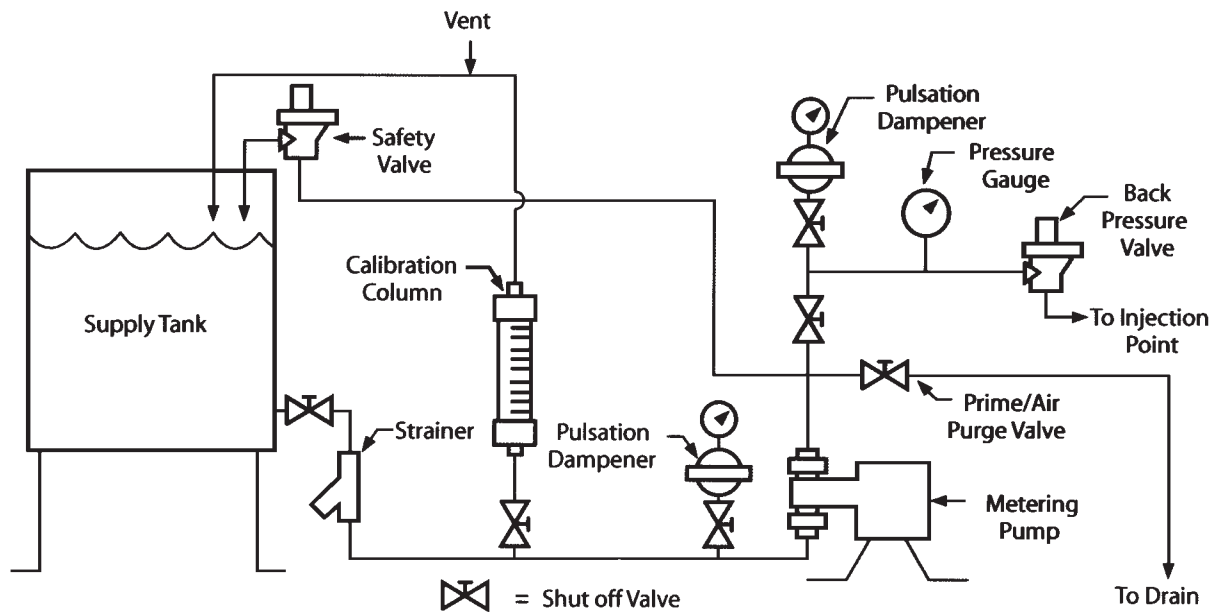

Figure 5 Typical Installation

THIS PAGE INTENTIONALLY BLANK

SECTION 4 OPERATION

INITIAL START-UP

After installing the pump perform the following operations before placing the pump in routine service.

Do not operate the pump without liquid in the liquid end. Purge air to ensure proper operation.

A note about pump start-up time: Once the required steps are completed and the unit is running, patience is necessary until all air has been removed from the hydraulic chambers and fluid. This may take an hour or in some cases overnight. It is helpful at the initial start-up to relieve the discharge pressure so that fluid and air can evacuate more easily. Once this natural air purge occurs, the pump flow will increase to meet the rating. Inadequate flow, in most cases means more running time is required until proper operation can be achieved.

1. Connect all piping and purge air as required.
2. Fill drive-end chamber (the end with gears and connecting rod) to the top of the cross-head with SHC 629 or other approved gear oil.
3. Fill the displacement chamber through each of the three towers located on the top of the displacement chamber with Zurnpreem 15A (or suitable) hydraulic oil. The towers contain the entire volume of hydraulic oil required

NOTE: The catchall chamber, located between the displacement chamber and the main drive end, normally runs dry for the low flow disc diaphragm design. Gear oil can carry over to this chamber if the oil level is too high, or if the cross-head seal leaks. Hydraulic oil can carry over to this chamber if the plunger seal leaks, or, if the displacement chamber sealing screws are not installed. These 1/4-20nc-1/2 screws are located in the rear displacement chamber. To inspect these screws, the displacement chamber must be removed from the main drive housing. Normally, these fasteners are installed at the Milton Roy Company, and do not require inspection or service.

to operate the diaphragm liquid end. The towers contain the air bleed/relief valve assembly, the hydraulic chamber vent, and the hydraulic site glass. Each tower should operate approximately one half full during normal operation. The sight glass and vent plugs should remain off until after completion of initial start up. After initial new pump start up, it is not necessary to remove these items during subsequent starting procedures.

4. Loosen the oil refill valve assy, located under the displacement chamber, and allow a small amount of hydraulic oil to drain out from this location. This will allow hydraulic oil to fill all internal cavities. Re-tighten the oil refill valve assy. Re-check the oil level in the towers. Top off if required. It is not necessary to perform this step after the new unit start up is completed. The oil refill valve does not require adjustment after initial start up, or during normal operation.
5. Purge air to ensure proper operation. Adjust the relief valve hex-head screw counter clockwise to relieve the pressure and allow oil and air to flow as required during start up.
6. Check motor rotation. A pump rotation arrow is located on the motor flange. Proper motor rotation is required for pump operation. Additional information regarding the operation and start-up of the Milroyal drive can be found in instruction manual 339-0010-000.
7. Set the micrometer pump stroke adjustment knob at zero percent (0%).
8. Check to make sure that all process supply and discharge valves are open. Inspect the process system for leaks. Verify that all necessary accessories are installed.
9. Start the pump.

WARNING:

KEEP HANDS AWAY FROM RECIPROCATING PLUNGER, CROSSHEAD, AND GEARS.

10. Listen for unusual noises in the drive assembly and motor.
11. Adjust the micrometer stroke adjustment

knob to one hundred percent (100%).

12. Inspect the towers on the displacement chamber. Hydraulic oil should be rising and falling during the stroking sequence of the pump. Remaining air that is trapped in the displacement chamber will be purged through the relief valve tower.

13. Slowly adjust the relief valve hex screw clockwise until the pump begins to build pressure. Normally, the pressure relief valve is factory set to open at a pressure slightly above the pump maximum operating discharge pressure. Do not set the valve at pressures greater than 3500 PSIG.

NOTE: To adjust the relief valve first operate the pump against a system operating pressure.

1. Install a pressure gauge, with a range higher than the desired relief pressure at the pump discharge connection.
2. Install a shut-off valve downstream from the pressure gauge.
3. Set micrometer control knob to 50% capacity.
4. Open shut off valve. Start pump; pump process liquid to drain or other safe point to establish proper pumping action.

WARNING:

OPERATING THE LOW FLOW DISC DIAPHRAGM AT PRESSURES HIGHER THAN 3500 PSIG AND A CLOSED DISCHARGE LINE MAY CAUSE EQUIPMENT DAMAGE OR BODILY HARM. CONTACT THE Milton Roy Company IF PROPER RELIEF VALVE ADJUSTMENT CANNOT BE ACHIEVED.

5. Close shut off valve ("dead head" the pump) and closely watch pressure increase on pressure gauge.

Adjust the hydraulic relief valve hex head screw until the proper set pressure is achieved. If pressure exceeds desired value, quickly open shut off valve to relieve pressure in process line.

6. Loosen relief valve adjustment screw and repeat step 5 until maximum pressure gauge reading equals the relief valve pressure setting desired.

7. After setting the relief valve, ensure shutoff valve is fully open. Remove pressure gauge from line, or leave in place, as desired, and place pump in routine service.

MAINTENANCE

Hydraulic Oil:

Inspect and replace hydraulic oil on the schedule provided.

Oil in gearbox: Mobil SHC 629.

Oil in displacement chamber: MIL-H-5606A or ATF.

CAUTION:

Do not install check valves in the improper direction. Install check valves with the flow arrow pointing in the direction of process flow (ie. suction side arrow points into the liquid end; discharge side arrow points out of the liquid end.

Turn check valve assemblies into liquid end by hand. Do not overtighten, damage to the check valves may occur.

CHECK VALVES

Maintain and service ball-check valves according to those instructions included in manual 339-0010-000.

Low flow disc diaphragm pumps have had several design changes and check valves are not interchangeable (See table 1). Before buying RPM kits for units in the field, contact factory service.

DISASSEMBLY

Remove and disassemble check valves as follows:

1. Unscrew check valve assembly from diaphragm head.
2. Reassemble check valves in reverse order from disassembly. During reassembly, tighten cartridge assembly nuts carefully to avoid stripping ports.

DIAPHRAGM

Disassembly- Remove diaphragm head as follows:

1. Flush process liquid from liquid end.
2. Disconnect piping from suction and discharge ball-check cartridges.
3. Remove bolts from diaphragm head and remove head from displacement chamber.

CAUTION:

PROCESS SIDE CONTOUR PLATE AND DIAPHRAGM RETURN BUTTON MAY COME AWAY WITH DIAPHRAGM HEAD.

4. Remove diaphragm from displacement chamber.

REASSEMBLY

Clean all parts for reassembly, then proceed as follows:

1. Set process side contour plate in diaphragm head. Replace spring and diaphragm return button as shown. Set new diaphragm in head over contour plate and button.
2. Press the diaphragm and the button to compress spring into the diaphragm head. Align diaphragm in shallow counter bore in the diaphragm head.
3. Place the head flat half way across the displacement chamber, while holding the button and diaphragm compressed. While holding the head against the displacement chambers slide the head across the displacement chamber and align bolt holes.
4. Mount diaphragm head assembly to displacement chamber with six socket head bolts.
5. Tighten bolts evenly and securely to ensure proper sealing of diaphragm. Torque to 50 ft-lbs.
6. Reconnect suction and discharge lines.
7. Test pump for leaks and then return to normal service.

DATE	KIT NUMBER	NOMENCLATURE	MATERIAL		
Before 1/1/01	RPM037	Routine Maint. Kit, Mill D, 1/4" NPT Conn, (Female)	316SS		
1/1/01 - 1/1/02	RPM038	Routine Maint. Kit, Mill D Checks, 1/4 NPT Both Ends, (Male)	316SS		
1/1/01 - 1/1/02	RPM127	Routine Maint. Kit, MIL D Double Ball	316SS		
1/1/01 - 1/1/02	RPM079	Routine Maint. Kit, MDD035 AL-20, 1/4 NPT Both Ends, (Male)		AL-20	
1/1/01 - 1/1/02	RPM080	Routine Maint. Kit, MDD036 HC-22, 1/4 NPT Both Ends, (Male)			HC-22
After 1/1/02	RPM130	Routine Maint. Kit, MIL D Double Ball with Face Seal	316SS		
After 1/1/02	RPM190	Routine Maint. Kit, MIL D Double Ball with Face Seal		AL-20	
After 1/1/02	RPM191	Routine Maint. Kit, MIL D Double Ball with Face Seal			HC-22

Table 1. Routine Maintenance Kits

THIS PAGE INTENTIONALLY BLANK

SECTION 5 TROUBLESHOOTING GUIDE

Pump will not operate	<ul style="list-style-type: none"> • Liquid level is low. • Blocked discharge line. • Liquid is frozen. • Fuse is blown. • Open thermal overload device in starter. • Broken wire. • Low voltage. 	<ul style="list-style-type: none"> Add liquid. Clear line. Thaw liquid through pumping system. Replace fuse. Reset device. Locate and repair. Investigate and correct (wiring may be too small).
Pump not primed.	<ul style="list-style-type: none"> • Allow suction line and pump head to fill with liquid before pumping against pressure. • Air trapped in hydraulic system. 	<ul style="list-style-type: none"> Loosen air bleed/relief valve assembly and allow excess air to escape. Re-set airbleed.
Insufficient delivery	<ul style="list-style-type: none"> • Incorrect capacity adjustment. • Incorrect pump speed. • Trapped air in hydraulic cavities. • Starved suction. • Leaky suction piping. • High suction lift. • Liquid near boiling. • Leaky safety valve in discharge line • High liquid viscosity. • Worn or dirty check valve seats. 	<ul style="list-style-type: none"> Readjust capacity setting. Match line voltage and frequency to pump motor data plate. Adjust oil relief valve counter-clockwise to remove pressure. Repeat process of relieving pressure, observe air, operate without pressure. Increase piping size or suction head. Repair piping. Rearrange equipment to decrease lift. Cool liquid or increase suction head. Repair or replace safety valve. Reduce viscosity (e.g., heat or dilute liquid). Clean or replace
Erratic delivery	<ul style="list-style-type: none"> • Leaky suction piping. • Leaky packing. • Leaky safety valve. • Insufficient suction head. • Liquid near boiling. • Worn or dirty valve seats. • Clogged or dirty line strainer. 	<ul style="list-style-type: none"> Repair packing. Adjust or replace packing. Repair or replace safety valve. Raise suction tank level or pressurize tank. Cool liquid or increase suction head. Clean or replace. Clean strainer.
Motor overheating	<ul style="list-style-type: none"> • Totally enclosed and explosion proof motors run hotter than open motors. • Wrong or insufficient gear case lubricant. Check oil level and type. • Operation beyond rated capacity. • Incorrect power supply. • Misalignment. 	<ul style="list-style-type: none"> Replace questionable lubricant. Constrain operation to specifications. Match line voltage and frequency to pump motor data plate. Check alignment of moving parts.
Gear Oil in Catch-All	<ul style="list-style-type: none"> • Gear oil level too high 	
Hydraulic Oil in Catch-All	<ul style="list-style-type: none"> • Worn plunger seal. • Displacement chamber sealing screws loose. 	

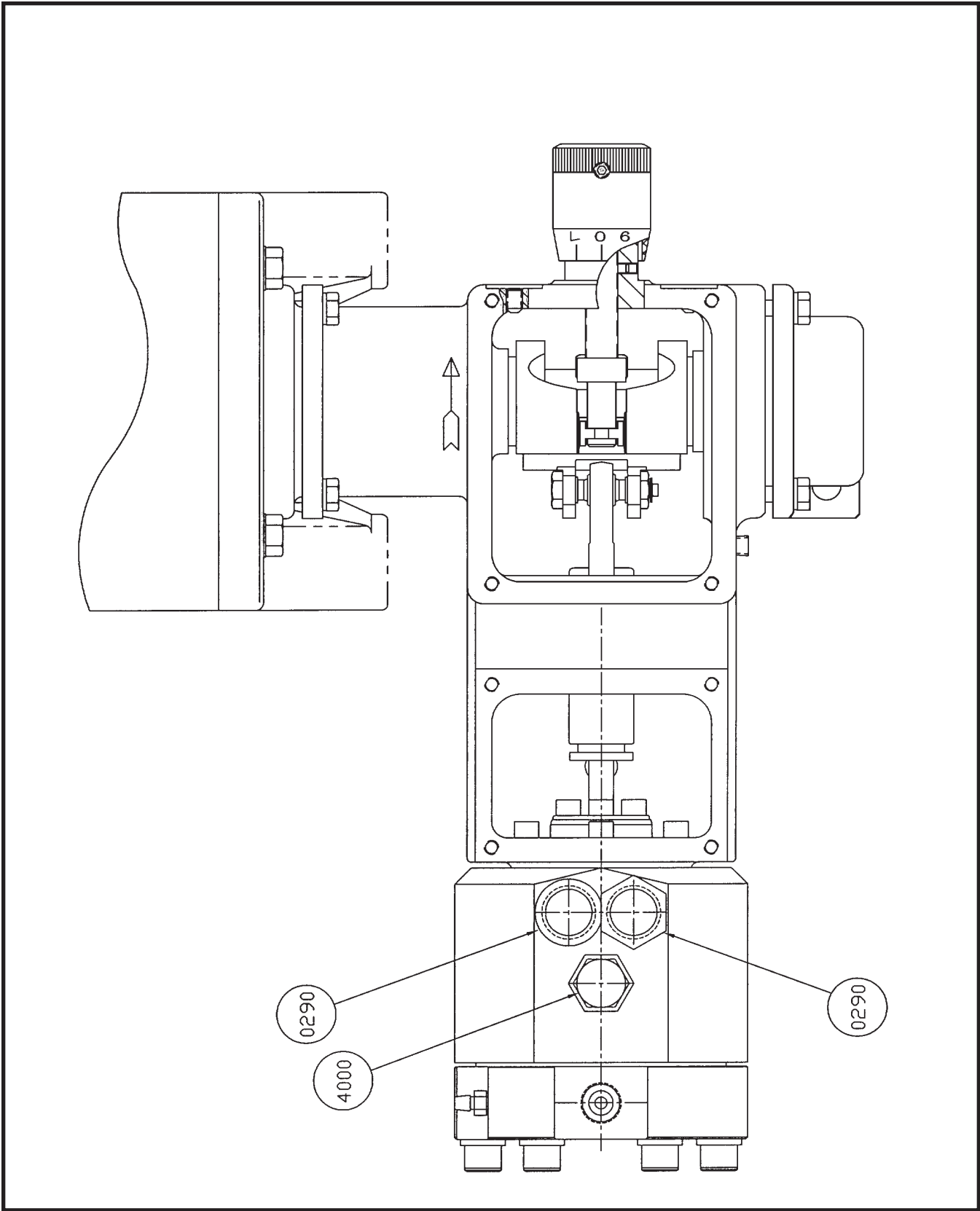

FIGURE 6
MILROYAL D DISC DIAPHRAGM LIQUID END top view

LIQUID END ASSEMBLY

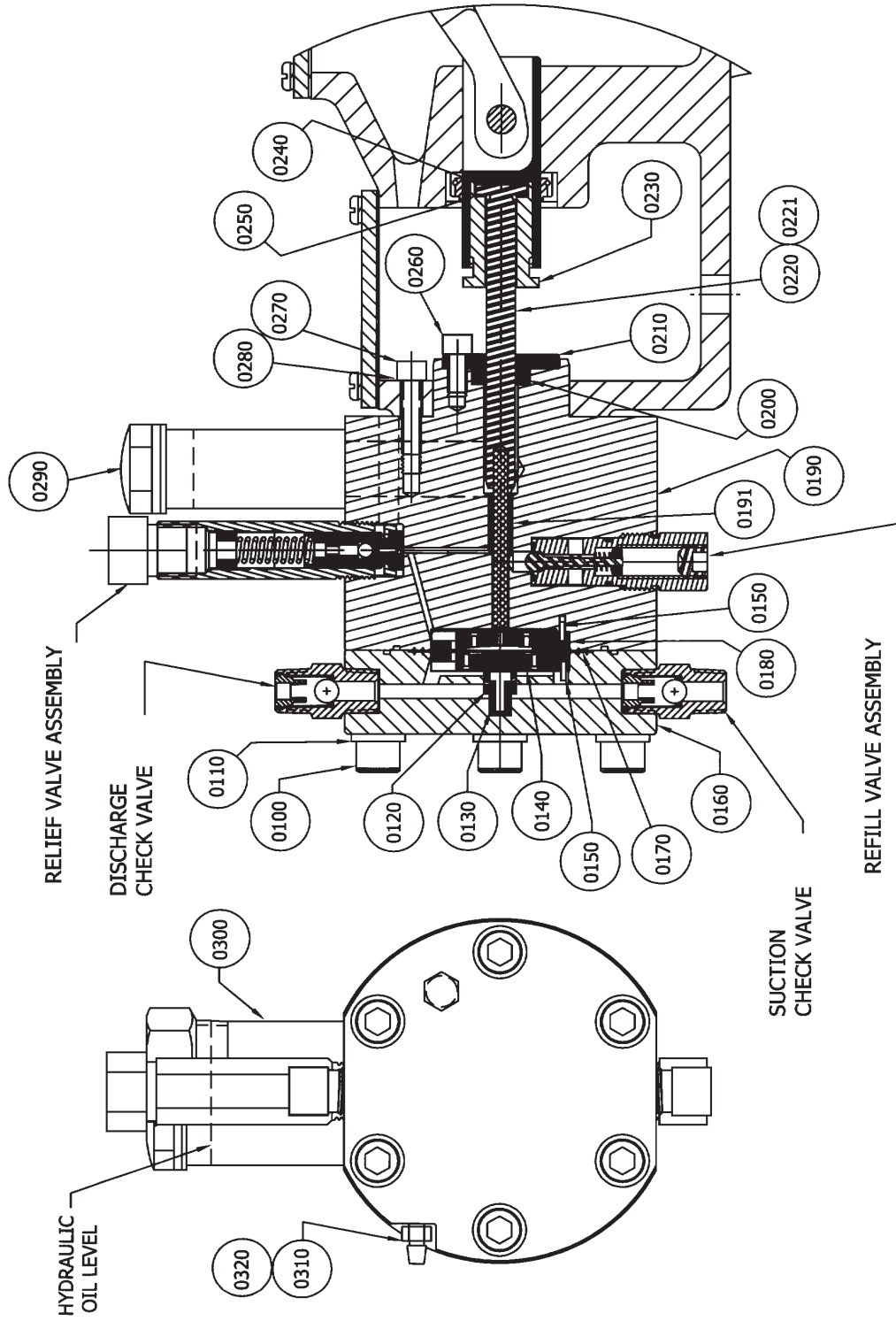

FIGURE 7

MILROYAL D DISC DIAPHRAGM LIQUID END section view

FIGURE 6 & 7

PARTS LIST FOR LIQUID END ASSEMBLY (PLUNGER DIAMETERS 1/8" & 3/16")

Item	Description	Part Number	Quantity	316SS	Alloy-20	Alloy-C22
0100	Screw, Socket Head 3/8-16 X 1-3/4	405-0029-154	6	X	X	X
0110	Washer 3/8 SAE, Plated	40476	6	X	X	X
0120	Spring - Diaphragm Return	20626	1	X	X	X
0130	Return Button, 316SS	20546	1	X		
	Return Button, Alloy-20	20995	1		X	
	Return Button, Alloy-C22	21006	1			X
0140	Process Side Contour Plate, 316SS	20569	1	X		
	Process Side Contour Plate, Alloy-20	20996	1		X	
	Process Side Contour Plate, Alloy-C22	21005	1			X
0150	Spring Pin 0.062x5/16 Steel	401-0001-031	2	X	X	X
0150	Spring Pin 0.062x5/16 18-8 SS	401-0001-033	2	X	X	X
0160	Diaphragm Head, Low Flow	21344	1	X		
	Diaphragm Head, Alloy-20	21345	1		X	
	Diaphragm Head, Alloy-C22	21346	1			X
0170	Diaphragm Teflon 0.030 Thick	20550	1	X	X	X
0180	Contour Plate, Oil Side, Low Flow	20993	1	X	X	X
0190	Displacement Chamber	21001	1	X	X	X
0191	Sleeve 0.125 Id X 0.313 Od X 3/4	20465	1	X / 1/8	X / 1/8	X / 1/8
0191	Sleeve 0.188 Id X 0.313 Od X 3/4	20466	1	X / 3/16	X / 3/16	X / 3/16
0200	Plunger Seal, Viton	20461	1	X	X	X
0210	Gland Cap 304 SS	20452	1	X	X	X
0220/0221	1/8" Plunger and Plunger Holder	20486	1	X / 1/8	X / 1/8	X / 1/8
0220/0221	3/16" Plunger and Plunger Holder	20485	1	X / 3/16	X / 3/16	X / 3/16
0230	Floating Plunger Nut 416 SS	272-9997-017	1	X	X	X
0240	Thrust Washer Disc	219-9999-052	1	X	X	X
0250	Thrust Washer Ring	219-9998-052	1	X	X	X
0260	Soc Hd Scr 1/4-20x5/8 18.8 SS	405-0027-085	3	X	X	X
0270	Soc Hd Scr 1/4-20x1 Alloy	405-0027-111	3	X	X	X
0280	Flat Washer 1/4 18.8 SS	404-0005-012	3	X	X	X

PARTS LIST FOR LIQUID END ASSEMBLY FIGURES 6 & 7, CONT.

Item	Description	Part Number	Quantity	316SS	Alloy-20	Alloy-C22
0290	Sight Glass 1/2 BSP Thread	20455	1	X	X	X
0300	Breather Cap 1/2 NPT	20596	1	X	X	X
0310	Barb, Air Bleed, 316 SS	20352	1	X		
	Barb, Air Bleed, Alloy-20	20528	1		X	
	Barb, Air Bleed, Alloy-C22	21010	1			X
320	O-Ring 2-007 - 90 Durometer	40466	1	X		
9001	1/4: NPT Double Ball Check Valve, Suction, Used before 01/01/01, See Figure 8	221-9997-128	1	X		
9002	1/4: NPT Double Ball Check Valve, Discharge, Used before , See Figure 8	221-9997-228	1	X		
9001/ 9002	1/4: NPT Single Ball Check Valve, Used between 01/01/01 and 01/01/02, Replaced by 21342, See Figure 9	21082	1	X		
	1/4: NPT Single Ball Check Valve, Used between 01/01/01 and 01/01/02, Replaced by 21326, See Figure 9	21085	1		X	
	1/4: NPT Single Ball Check Valve, Used between 01/01/01 and 01/01/02, Replaced by 21343, See Figure 9	21086	1			X
	1/4: NPT Single Ball Check Valve, Used between 01/01/01 and 01/01/02, See Fig. 9	21342	1	X		
	1/4: NPT Double Ball Check Valve, Used between 01/01/01 and 01/01/02, See Fig. 9	21326	1		X	
	1/4: NPT Double Ball Check Valve, Used between 01/01/01 and 01/01/02, See Fig. 9	21343	1			X
9001	1/4: NPT Double Ball Check Valve, Suction, Used After 01/01/02, See Figure 10	30733	1	X		
	1/4: NPT Double Ball Check Valve, Suction, Used After 01/01/02, See Figure 10	30722	1		X	
	1/4: NPT Double Ball Check Valve, Suction, Used After 01/01/02, See Figure 10	30735	1			X
9002	1/4: NPT Double Ball Check Valve, Discharge, Used After 01/01/02, See Figure 10	30734	1	X		
	1/4: NPT Double Ball Check Valve, Discharge, Used After 01/01/02, See Figure 10	30723	1		X	
	1/4: NPT Double Ball Check Valve, Discharge, Used After 01/01/02, See Figure 10	30736	1			X

**FIGURE 8
DOUBLE BALL SUCTION & DISCHARGE VALVE
USED BEFORE 01/01/01**

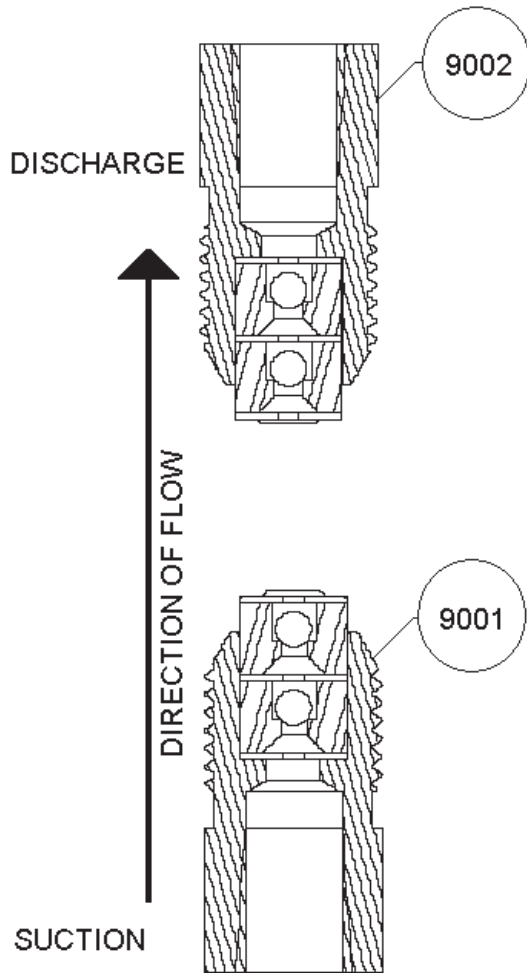

WARNING: IMPROPER VALVE ASSEMBLY WILL CAUSE EQUIPMENT DAMAGE AND MAY CAUSE BODILY HARM.

Item Number	Nomenclature	Part Number	Quantity	Material
Figure 8	1/4" NPT Double Ball Check Valve*			
9001	Suction Valve Assembly	221-9997-128	1	A-20
9002	Discharge Valve Assembly	221-9997-228	1	A-20

* USED BEFORE 01/01/01, USED FOR 316SS AND A-20 LIQUID END

THIS PAGE INTENTIONALLY BLANK

FIGURE 9
SINGLE BALL AND DOUBLE BALL CHECK VALVE ASSEMBLIES
USED BETWEEN 01/01/01 and 01/01/02

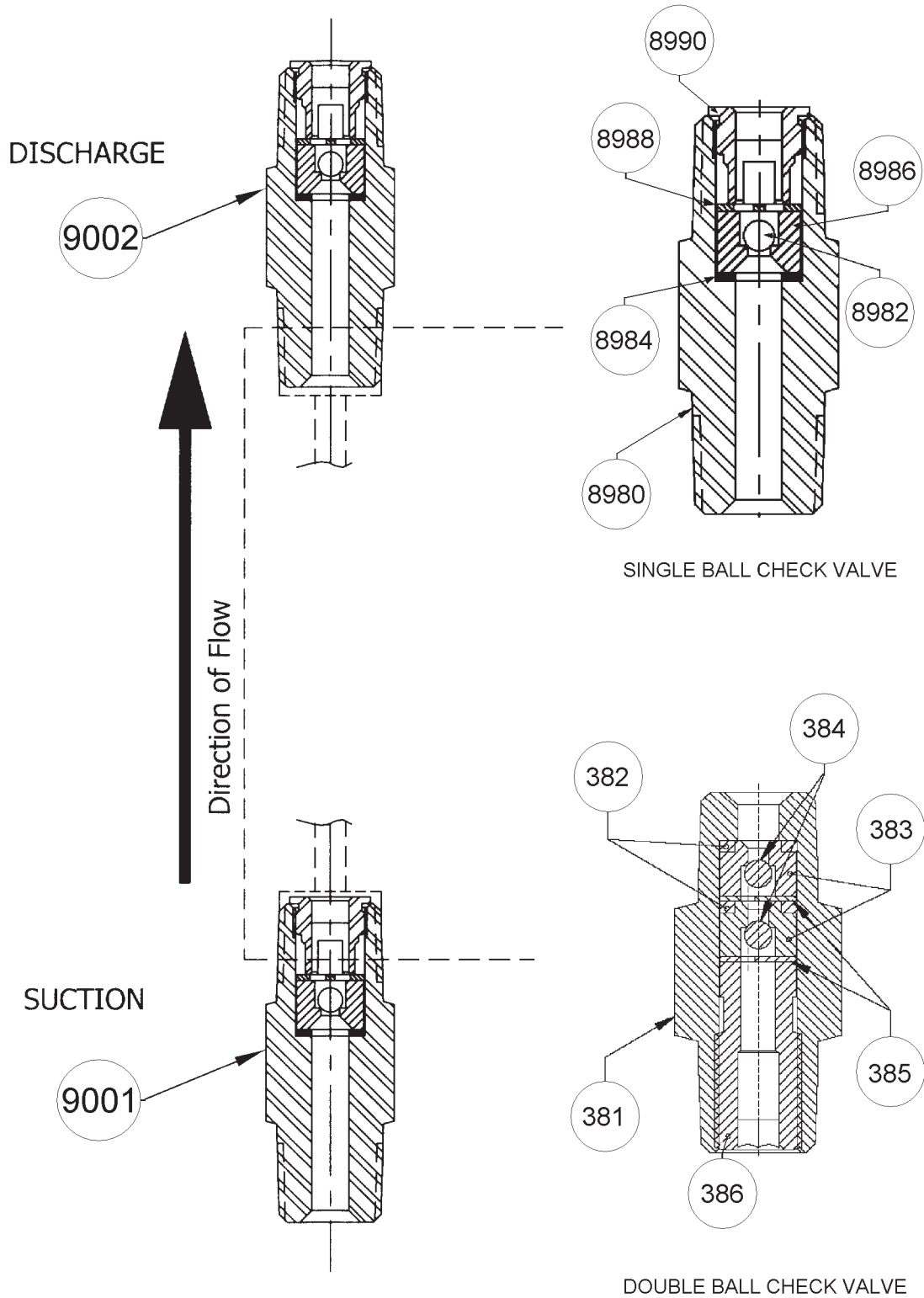

Item Number	Nomenclature	Part Number	Quantity	Material	Single Ball Reference Code	Double Ball Reference Code
Figure 9 9001/9002	1/4: NPT Check Valve*, Replaced by P/N 21342	21082	2	316SS	A	
	1/4: NPT Check Valve*, Replaced by P/N 21326	21085	2	ALLOY-20	B	
	1/4: NPT Check Valve*, Replaced by 21343	21086	2	ALLOY-C22	C	
	1/4: NPT Check Valve*	21342	2	316SS		D
	1/4: NPT Check Valve*	21326	2	ALLOY-20		E
	1/4: NPT Check Valve*	21343	2	ALLOY-C22		F
8980	Check Valve Body	CV202285	1	316SS	A	
	Check Valve Body	20997	1	ALLOY-20	B	
	Check Valve Body	21007	1	ALLOY-C22	C	
8982	Ball Check 1/8"	407-0014-033	1	ALLOY-20	A, B	
	Ball Check 1/8"	407-0014-036	1	ALLOY-C22	C	
8984	O-Ring/Teflon	T-009	1		A, B, C	
8986	Seat	20989	1	ALLOY-20	A, B	
	Seat	21009	1	ALLOY-C22	C	
8988	Ball Stop	21283	1		A, B, C	
8990	Retainer Sleeve	CV202287	1	316SS	A	
	Retainer Sleeve	20998	1	ALLOY-20	B	
	Retainer Sleeve	21008	1	ALLOY-C22	C	
381	Check Valve Body	21336	1	316SS		D
	Check Valve Body	21325	1	ALLOY-20		E
	Check Valve Body	21338	1	ALLOY-C22		F
382	O-Ring/Teflon	T-009	2			D, E, F
383	Seat 1/8 Ball	21391	2	316SS		D
	Seat 1/8 Ball	21285	2	ALLOY-20		E
	Seat 1/8 Ball	21340	2	ALLOY-C22		F
384	Ball Check 1/8", Grade-25	41020	2	316SS		D
	Ball Check 1/8"	407-0014-033	2	ALLOY-20		E
	Ball Check 1/8"	407-0014-036	2	ALLOY-C22		F
385	Valve Cap Ball Stop	21283	2			D, E, F
386	Retainer 1/8 Ball	21337	1	316SS		D
	Retainer 1/8 Ball	21287	1	ALLOY-20		E
	Retainer 1/8 Ball	21339	1	ALLOY-C22		F

* USED BETWEEN 01/01/01 and 01/01/02

**FIGURE 10
DOUBLE BALL SUCTION & DISCHARGE VALVE
USED AFTER 01/01/02**

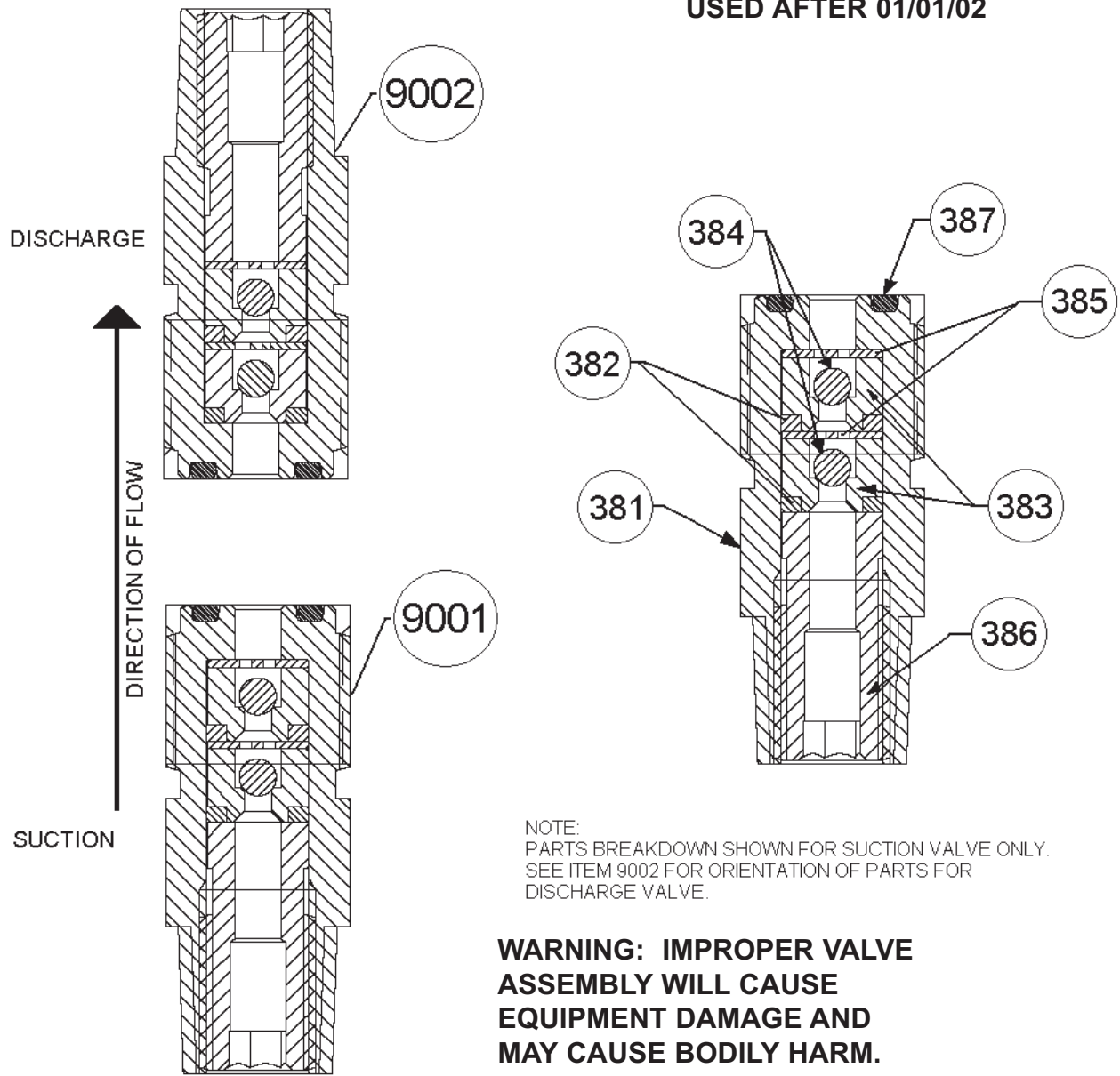

NOTE:
PARTS BREAKDOWN SHOWN FOR SUCTION VALVE ONLY.
SEE ITEM 9002 FOR ORIENTATION OF PARTS FOR
DISCHARGE VALVE.

**WARNING: IMPROPER VALVE
ASSEMBLY WILL CAUSE
EQUIPMENT DAMAGE AND
MAY CAUSE BODILY HARM.**

Item Number	Nomenclature/Material	Part Number	Quantity	Reference Code
Figure 10	1/4" NPT Double Ball Check Valve*			
9001	Suction Valve Assembly, 316SS	30733	1	A
	Suction Valve Assembly, Alloy 20	30722	1	B
	Suction Valve Assembly, Alloy C-22	30735	1	C
9002	Discharge Valve Assembly, 316SS	30734	1	D
	Discharge Valve Assembly, Alloy 20	30723	1	E
	Discharge Valve Assembly, Alloy C-22	30736	1	F

* USED AFTER 01/01/02

Item Number	Nomenclature	Part Number	Quantity	Reference Code
Figure 10	1/4: NPT Double Ball Check Valve Cont.*			
381	Check Valve Body, 316SS	21347	1	A, D
	Check Valve Body, Alloy 20	21284	1	B, E
	Check Valve Body, Alloy C-22	21348	1	C, F
382	O-Ring/Teflon	T-009	2	A, B, C, D, E, F
383	Seat	21391	2	A, D
	Seat	21285	2	B, E
	Seat	21340	2	C, F
384	Ball, Alloy 20	407-0014-033	2	A, B, D, E
	Ball, Alloy C-22	407-0014-036	2	C, F
385	Ball Stop	21283	2	A, B, C, D, E, F
386	Retainer, 316SS	21337	1	A, D
	Retainer, Alloy 20	21287	1	B, E
	Retainer, Alloy C-22	21339	1	C, F
387	O-Ring, Teflon Encap Viton	40920	1	A, B, C, D, E, F

* USED AFTER 01/01/02

FIGURE 11
REFILL VALVE ASSEMBLY

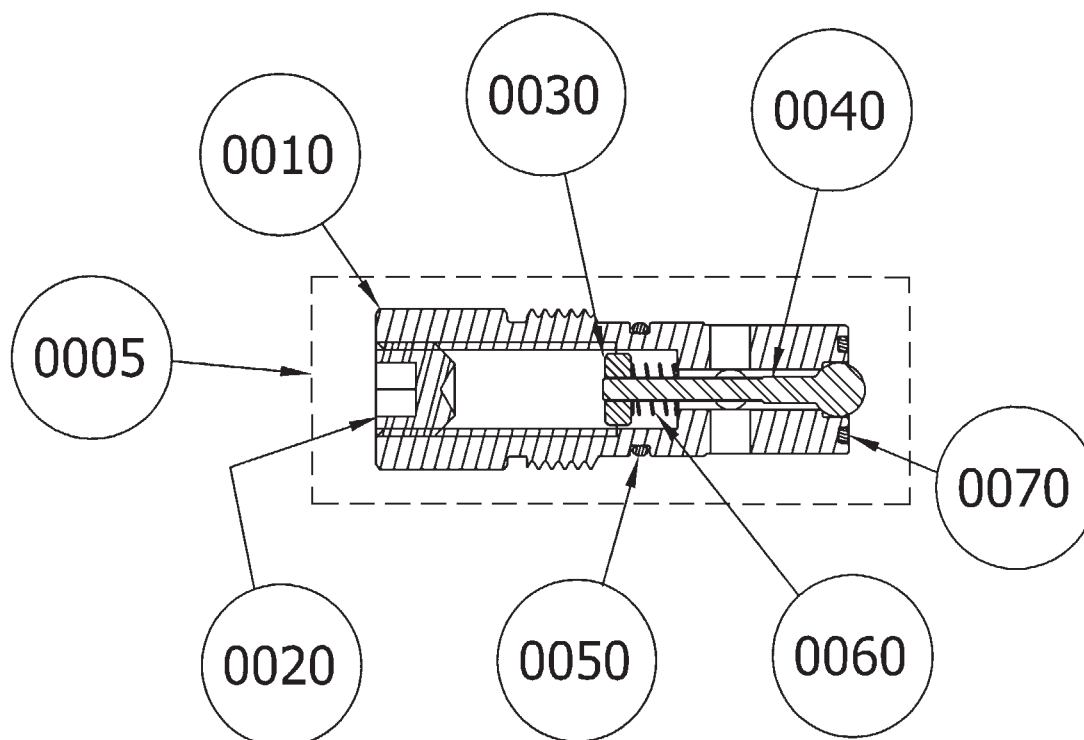

PARTS LIST FOR REFILL VALVE ASSEMBLY

Item Number	Nomenclature	Part Number	Quantity	Recommended Maintenance Items
Figure 11	Refill Valve Assembly	20472		long term
0010	Refill Valve Body	20581	1	
0020	Set Screw Plug	40468	1	
0030	Retaining Nut	405-0182-012	1	
0040	Ball Poppet	20022	1	
0050	O-Ring	40069	1	
0060	Spring	20024	1	
0070	O-Ring	408-9996-012	1	

“long term” items are recommended for stock as long term spares.

ASSEMBLY NOTES:

1. Ball poppet must be coined to refill valve body using mechanics mallet.
2. Adjust retaining nut and vacuum test poppet for 3 PSI vacuum opening pressure.
3. Air pressure test ball poppet assembly at 20 PSIG line pressure for poppet/seat seal.

FIGURE 12
RELIEF VALVE ASSEMBLY

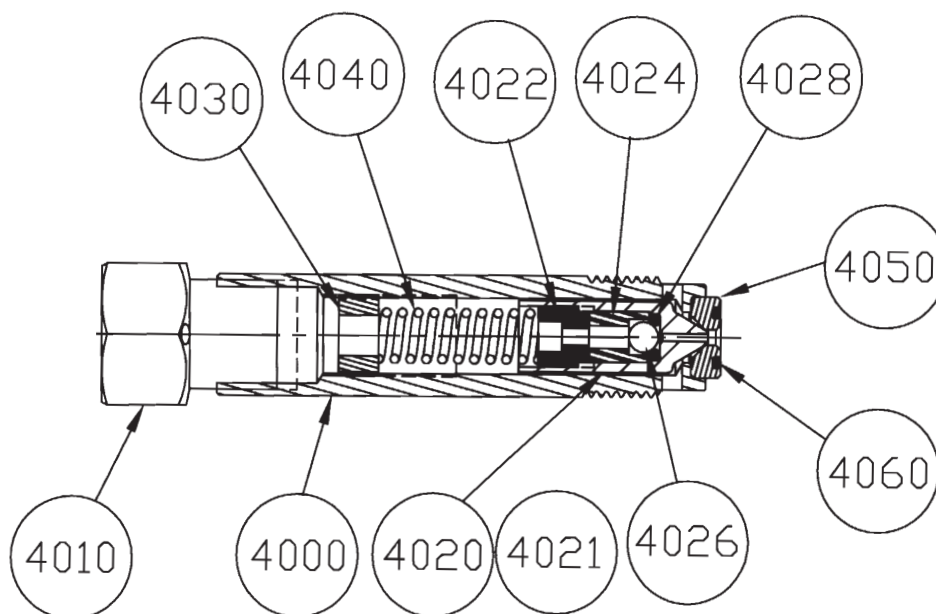

PARTS LIST FOR RELIEF VALVE ASSEMBLY - 20763 (DRAWING NUMBER 102-2315-000)

Item Number	Nomenclature	Part Number	Quantity	Recommended Maintenance Items
Figure 12	Relief Valve Assembly	20763		
4000	Relief Valve Body	20578	1	
4010	Breather Cap	20595	1	
4020	Poppet Assembly**	20538	1	long term
4021	Poppet (1 ea)	20579		
4022	Retaining Screw (1 ea)	20585		
4024	Spacer Seat (1 ea)	20580		
4026	3/16" Ball (1 ea)	407-0014-050		
4028	O-Ring (1 ea)	40466		
4030	Adjustment Screw	40467	1	
4040	Relief Spring	40470	1	
4050	Relief Valve Seat**	20577	1	long term

"long term" items are recommended for stock as long term spares.

** - these parts are to be replaced at the same time.

NOTE:

Unit designed to operate with relief valve assembly partially filled with hydraulic oil.

Milton Roy Company • Flow Control Division

201 Ivyland Road • Ivyland, PA 18974-0577 • 215-441-0800 • FAX: 215-441-8620 • www.miltonroy.com

This document contains proprietary information of Milton Roy Company. Neither receipt nor possession thereof confers any right to reproduce, modify, use, or disclose, in whole or in part, any such information without written authorization from Milton Roy Company. Please reference Milton Roy General Terms and Conditions of Sale. Milton Roy Company owns all trademarks and registered trademarks of products listed.